

VOCIA® Wall Station (WS-10) DATA SHEET



The WS-10 is a wall-mounted networked paging station for use in Vicia® systems. The WS-10 features embedded DSP and on-board memory to support standard and advanced public address functionalities. The WS-10 can store 999 user-configurable page codes. Additionally, all device-specific configuration information is stored locally, which means the WS-10 does not rely on a centralized controller for processing and page routing. Thus, the processing, routing and storage functionality in a Vicia system is decentralized, which eliminates any centralized point of failure. As part of the Vicia system, the WS-10 meets paging requirements for facilities of all sizes.

FEATURES

- Push-to-talk button with status indication
- Up to 999 user-configurable page codes
- Eight priority levels: four regular and four emergency priority levels
- Local digital signal processing, including gain, filters, and compressor/limiter
- Local storage of configuration data
- Local storage of default and/or custom preambles
- Built-in store and forward functionality
- CobraNet® audio/control with dynamic use of available bundles, plus power over single Ethernet cable
- Backlit liquid crystal display (LCD) technology
- Optional PIN to restrict unauthorized use
- High-quality, noise-cancelling handheld microphone
- Sturdy, surface-mounted component housing
- Rotary ID switches for unit identification
- **CE** marked and **RoHS** compliant
- Covered by Biamp Systems' warranty

ARCHITECTS & ENGINEERS SPECIFICATION

The wall-mounted paging station shall be designed exclusively for use with Biamp® Vicia® systems. The wall-mounted paging station shall provide paging audio and control data via CobraNet®, and receive Power over Ethernet (PoE), utilizing a single (CAT5) network cable to a rear panel RJ45 connector. Ten buttons shall be provided on the front panel for recalling page codes with preambles. Multiple wall-mounted paging stations may be connected to a Vicia system by means of Ethernet switches. Up to eight paging priority levels shall be available. The wall mounted paging station shall include override, store and forward, and lock-out capabilities. Each wall-mounted paging station shall provide local digital audio signal processing, local storage of configuration data, and standard and uploaded preambles in .WAV format. Wall-mounted paging stations shall possess a backlit LCD screen, PIN code accessibility, and a high-quality, noise-cancelling handheld microphone. The wall-mounted paging station shall be CE marked and shall be compliant with the RoHS directive. Warranty shall be 5 years.

The wall-mounted paging station shall be a Vicia WS-10.

Wall Station 10 SPECIFICATIONS

Frequency Response (electronics):	+0,-1dB, 100Hz to 20kHz	A/D Converters:	24-bit (48kHz sampling)
Effective Input Headroom:	30dB	Connection:	RJ45 with shielded Ethernet/PoE cable (CAT5, CAT5e, CAT6, or CAT7)
Gain:	Adjustable in 1dB steps over a 30dB range	Power:	802.3af (PoE) Class 2
System Headroom:	18dB	Aux:	24V DC 6W
Maximum Input:	125dB SPL	Overall Dimensions (excl. microphone):	
THD + N (100Hz to 8kHz):	<0.05%	Height:	5.3 inches (135mm)
Mic Type:	dynamic	Width:	11.9 inches (302mm)
Mic Pattern:	noise cancelling cardioid	Depth:	1.9 inches (48mm)
Mic Frequency Response (1cm):	100Hz-10kHz	Mic Cord Length (extended):	4 ft. (1200mm)
		Weight:	Approx. 2.6 lbs. (1.2kg)
		Ambient Operating Temperature Range:	32-113 degrees F (0-45 degrees C)
		Compliance:	EU Directive 2002/95/EU, RoHS directive CE marked

Wall Station 10 WALL-MOUNTING BRACKETS

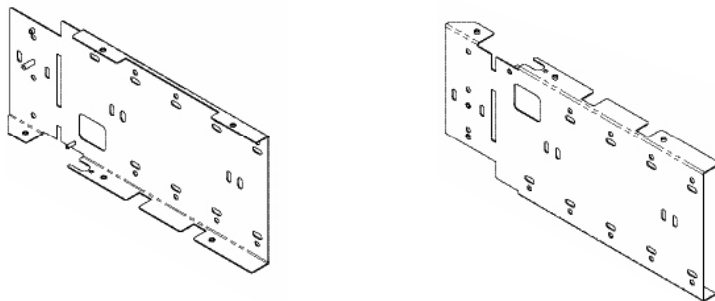

Wall Station 10 BLOCK DIAGRAM

