

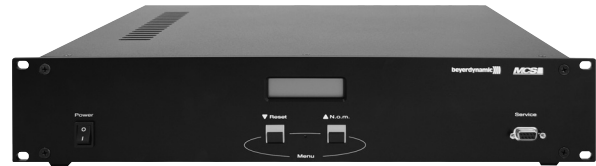

MCS 50 DISCUSSION CONTROL UNIT



FEATURES

- One microphone line for a maximum of 32 microphone units
- Integrated power supply unit with control for up to 32 microphone units
- Can be expanded to 64 microphone units
- Multifunction display for indication and configuration
- Multifunction buttons for menu control and system configuration without PC
- Master reset button to load default settings
- Service RS 232 interface port on the front for PC system configuration
- Supplied with "MCS-Editor" configuration software
- All inputs and outputs are plug-in type
- RS 232 connection for external operation via PC or media control system
- Control unit in a 2 U-housing, suitable for 19" rack mounting
- MCS Controller Software for Windows® operating systems available as an option

DESCRIPTION

- System check of all adjusted parameters
- Status check for error diagnosis
- Equalisation control for adjusting system's audio response
- Audio input for balanced line-level signals such as wireless receiver, mixing consoles, telephone hybrids etc.
- Unbalanced audio input for system extension
- Record output for direct connection to a recording system
- RS 232 interface allows the operation of the discussion system via PC or other available media control systems such as AMX®, Crestron®, Cue® etc. to enable complete conference room control.

Germany

Theresienstr. 8
D-74072 Heilbronn
Tel. +49 (0)71 31 / 6 17-0
Fax +49 (0)71 31 / 617-224
E-mail: info@beyerdynamic.de
Internet: www.beyerdynamic.de

United States

56 Central Ave.
Farmingdale, NY 11735
Tel. +1 (631) 293-3200
Fax +1 (631) 293-3288
E-mail: salesUSA@beyerdynamic.com
Internet: www.beyerdynamic.com

Great Britain

17 Albert Drive
Burgess Hill RH15 9TN
Tel. +44 (0)1444 / 258 258
Fax +44 (0)1444 / 258 444
E-mail: sales@beyerdynamic.co.uk
Internet: www.beyerdynamic.co.uk

- **System configuration set-up options:**

- Function of the microphone button
On/Off or PTT (Push-To-Talk, as long as the microphone button is pressed, the microphone unit is switched on).

- **Operation mode:**

- **Request-to-Talk**

- This mode is only possible with an operator manually controlling a PC or media control system (AMX® or Crestron®). Pressing the microphone button on the delegate unit the system registers a request-to-talk. The operator has control over the next speaker using a the PC or the console button.

- **Autonomy**

- Each participant can enable the microphone until the maximum number of open microphones (NOM) is achieved.

- **Override**

- Each selected microphone unit switches off the previously activated microphone unit.

- The talk time of the delegates can be pre-set. After the time has elapsed the microphone unit switches off.
- A flashing illuminated ring indicates the time when the microphone is switched off. The flashing illuminated ring can also be effected by an external control command (AMX/Panja®, Crestron®).
- **Chairman unit operational mode:**

- **Normal**

- The chairman can switch on his microphone without any limitation.

- **Mute**

- The priority button of the chairman's microphone unit will mute all activated delegate microphone units. When the priority button is released, all previously selected microphones are re-activated.

- **Clear**

- The chairman can switch off all active delegate microphone units using the priority button. They remain switched off until the chairman switches off his microphone unit by pressing the priority button.

- **NOM (number of open microphones):**
Defines the maximum number of delegate microphones that can be switched on (up to 9 microphone units).
- **Muting the speaker:**
When the microphone unit is switched on, it's own speaker is muted automatically. It is possible to mute up to 10 other microphone units (usually the surrounding units to reduce the possibility of acoustic feedback) as soon as the speaker is activated.

ARCHITECT'S SPECIFICATIONS

Central control unit as main item of the discussion system with conference media control. Integrated power supply unit and processor for digital control of up to 32 microphone units. 2 multifunction buttons and LC-Display with 2 lines/16 segments for menu driven system operation and configuration. RS 232 interface port on the front for system configuration with PC. System check with error message after switching on the device. Master reset to manufacturer's default settings. RS 232 interface for operator's PC or external console. Two inputs for sound signals 250 mV (balanced) and 1.55 V (unbalanced). The following three operation modes can be chosen: Request-to-Talk (after request-to-talk the chairman releases the microphone), Autonomy (each participant can switch on and off his microphone unit), Override (each switched on microphone unit switches off the previously activated microphone unit). "Next" function control (first in - first out) in the Request-to-Talk mode. In each operation mode it is possible to pre-set the talk time and warning time for each participant and for the illuminated ring to indicate that talk time has elapsed. The following parameters can be adjusted within the system configuration: number and address of the chairman microphone units, function of the priority button, number of the open microphones, number and address of the loudspeakers to be muted in the microphone units, input level of the signals and volume and sound control of the master signal. 1 connection for microphone line. Recording output (250 mV) and a 3-pin XLR socket for transformer balanced line level output (+6 dBm). Recording output is independent from the output volume adjustment. Desktop housing: 2 rack units high, for 19" rack mounting. Ventilation louvres on top and bottom. Dimensions (W x H x D) 440 x 88 x 310 mm. Weight 4850 g.

Manufacturer: beyerdynamic GmbH, Germany
Type: MCS 50

SYSTEM INSTALLATION

There is a system bus set up with one microphone line. Up to 32 microphone units can be connected.

The system connecting cable can be manufactured in special lengths and versions. Delivery period, price and more information available upon request.

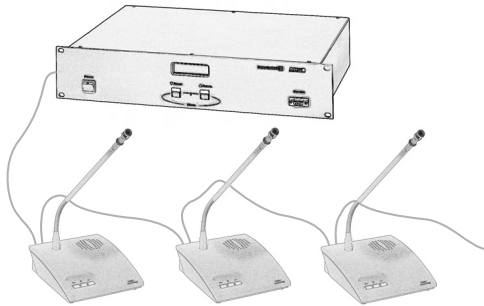

Single cable connection

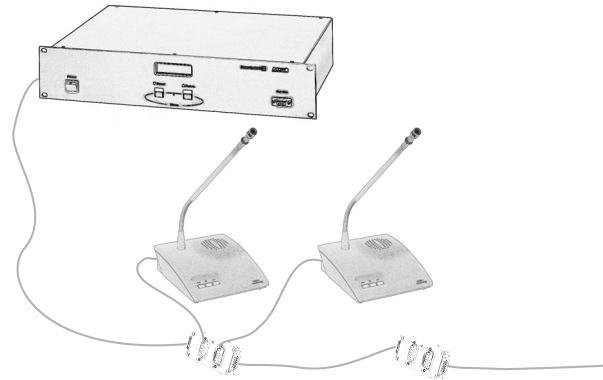

Branch cabling

ARCHITECT'S SPECIFICATIONS

3-way adapters in a compact, impact-resistant metal housing with a 15-pin Sub-D plug and three 15-pin Sub-D sockets. Two connections for delegate units and one connection for loop-through wiring.

Manufacturer: beyerdynamic GmbH, Germany
Type: CA 1513

Connecting cable with PVC outer jacket to connect the MCS components and adapters. 2.5 m long, flexible cable, in black with 15-pin Sub-D-coupling and connector. 3 x 2 x 0.08 sqmm coiled in the screen, 0.50 and 1 x 0.25 sqmm in the overall screen.

Manufacturer: beyerdynamic GmbH, Germany
Type: CA 1502

Connecting cable with PVC outer jacket to connect the MCS components and adapters. 10 m long, flexible cable, in black with 15-pin Sub-D-coupling and connector. 3 x 2 x 0.08 sqmm coiled in the screen, 0.50 and 1 x 0.25 sqmm in the overall screen.

Manufacturer: beyerdynamic GmbH, Germany
Type: CA 1510

Connecting cable with PVC outer jacket to connect the MCS components and adapters. Flexible cable, length upon request, in black with bare ends. 3 x 2 x 0.08 sqmm coiled in the screen, 0.50 and 1 x 0.25 sqmm in the overall screen.

Manufacturer: beyerdynamic GmbH, Germany
Type: CA 1500

TECHNICAL SPECIFICATIONS

Connections

Mains	IEC connector
RS 232 interface	9-pin Sub-D socket
Service RS 232 interface	9-pin Sub-D socket
AF input and AF output	3-pin XLR
Microphone Line	15-pin Sub-D socket
Display	LC-Display 2 x 16 characters
Switch - Button	ON/OFF-switch one Reset-Button for user specific adjustments one N.o.m-Button one Master-Reset-Button for manufacturer specific adjustments
Dimensions (W x H x D)	2 rack units high for desktop or 19" rack mounting (440 x 88 x 310 mm)
Weight	4850 g

Power supply units

Mains voltage	85 V to 264 V AC (50/60 Hz)
Output voltage	+24 V, +5 V, +15 V and -15 V
Power consumption	38 W (MCS 50/32) 60 W (MCS 50/64)
Output power at +24 V	6 A
Residual ripple	150 mVpp
Ambient temperature	0°C to +50°C
Humidity	max. 90%
Protective measurements	overload, short circuit and open circuit proof

Audio

Frequency response	80 Hz to 19,000 Hz
T.H.D.	≤ 1%
Bass control (shelving type)	± 12 dB at 150 Hz
Treble control (bell type)	± 12 dB at 7 kHz
Power supply	+24 V, +5 V, +15 V, -15 V
Power consumption	80 mA, 60 mA, 72 mA, 33 mA

MCS 50 Rear View

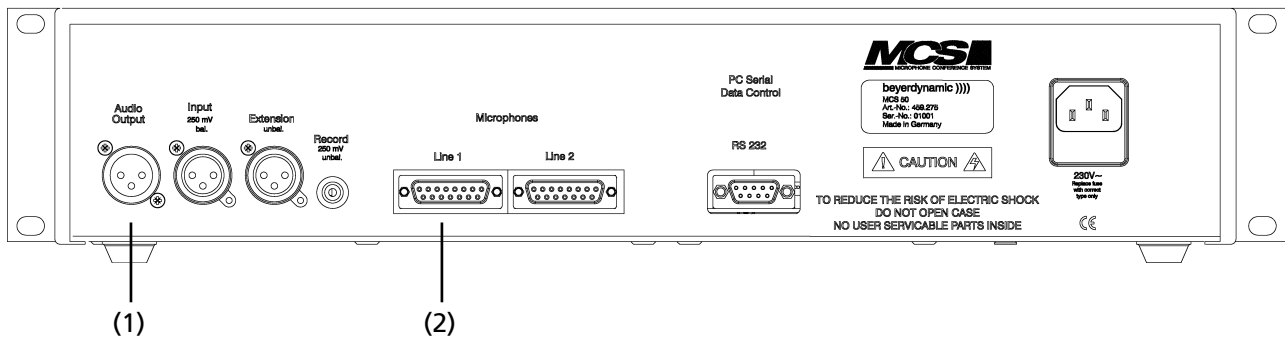

XLR-plug (1)

Line-output Pin 2+, 3- and 1 screen, balanced, floating, 1.55 V (+6 dBm)

Microphone Line 1 (2)

AF-input 0 Ohm master, pin 7+, 6- and 14 screen, balanced, floating, adjustable -40 dB
 AF-output 1.55 V (+6 dBm), Pin 5+, 4- and 12 screen, balanced, floating, adjustable -40 dB
 Power supply output Pin 1 and 9 +24 V, 6 A
 Data-Bus-line (CPU) Pin 2 = A, Pin 3 = B, Pin 10 = screen
 Max. cable length 300 m

CONNECTION SYSTEM CABLE

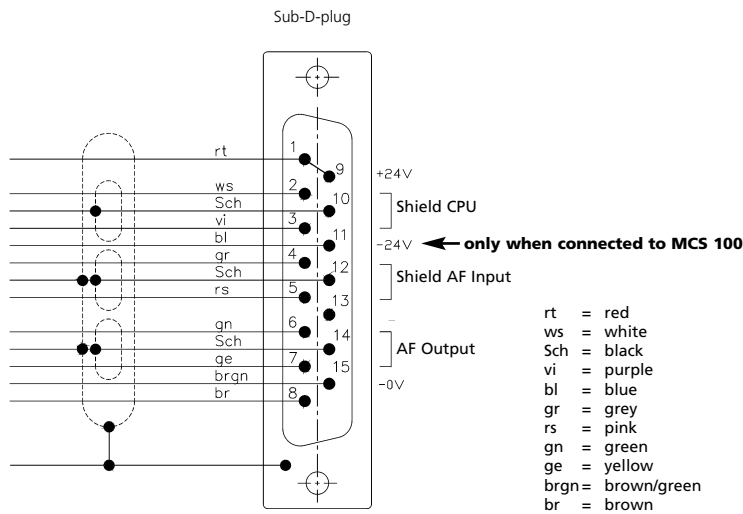

SPARE PARTS

Illu. No.	Part No.	Drawing No.	Description
10	553.093	BN 17-640/A	Casing, top
20	553.387	BN 17-644/A	Casing, bottom
30	322.881	Best.-Nr. 544.873 schwarz	Adhesive base
40	391.018	DIN 965-M 3 x 8	Countersunk screw
50	553.433	BN 56-990/A	Front panel
60	503.576	DIN 965-M 5 x 12	Countersunk screw
70	553.182	41 L 07563 600GNGE300	Wire
80	252.581	Nr. 1802.0102	Mains switch
90	535.419	B 24-635.00-00	Button panel
100	283.371	BN 37-36/5,7 (Alt/I)	Sleeve
110	142.727	DIN 934-M 3	Hexagonal nut
120	187.194	DIN 6797-J 3,2	Studded disc
130	538.698	B 24-642.00-00	LCD-Display
140	231.940	BN 37-36/7,5 (Alt/I)	Sleeve
150	142.727	DIN 934-M 3	Hexagonal nut
160	284.858	DIN 125-A 3,2	Disc
170	538.825	B 7-660.00-00	Connecting cable
180	516.791	4-40 UNC	Threaded bolt
190	552.518	KES 3SI	Appliance inlet
200	554.480	LEB150F-0524-Z35/SN	Power supply
210	554.464	B 21-67.00-00	Cable form
220	554.472	B 21-68.00-00	Cable form
230	545.473	H 19, 0XB19, 0XD 6,0	Adhesive base
240	529.834	PLT.65M-C B 1,8L 71D0,75	Cable binde
250	538.833	B 7-659.00-00	Connecting cable
260	321.303	DIN 965-M 4 X10	Countersunk screw
270	554.227	B 24-640.01-00	Processor panel
280	551.473	Best.-Nr. 680096	Spacing piece
290	391.018	DIN 965-M 3 X 8	Countersunk screw
300	553.794	BN 48-141/A	Spacing bolt
310	143.278	DIN 137-A 3	Spring washer
320	142.727	DIN 934-M 3	Hexagonal nut
330	553.514	B 24-698.00-00	Analogue panel
340	551.473	Best.-Nr. 680096	Spacing piece
350	391.018	DIN 965-M 3 X 8	Countersunk screw
360	553.794	BN 48-141/A	Spacing bolt
370	143.278	DIN 137-A 3	Spring washer
380	142.727	DIN 934-M 3	Hexagonal nut
390	122.424	DIN 7981-B 2,9 X 9,5	Sheet metal screw
8000	324.264	50,00 X 20,00 Al-matt	Sticker
9800	118.826	3 X 0,75	Mains cable

VERSIONS

MCS 50	Control unit for 32 microphone units	Order # 459.275
MCS 50-64	Control unit for 64 microphone units	Order # 463.388